

# SOP Training Dishwashing

## Standard and Procedures in the Stewarding Department



©2020 InnArchive.co. All Rights Reserved.  
CONFIDENTIAL & PROPRIETARY May not be reproduced or distributed without written permission of InnArchive.co

## Standard and Procedures

- Refilling dishwashing machine
- Setting up bussing station
- Scrapping, racking and loading the dishwasher
- Cleaning the dishwasher and traps inside the machine
- Avoid breakages

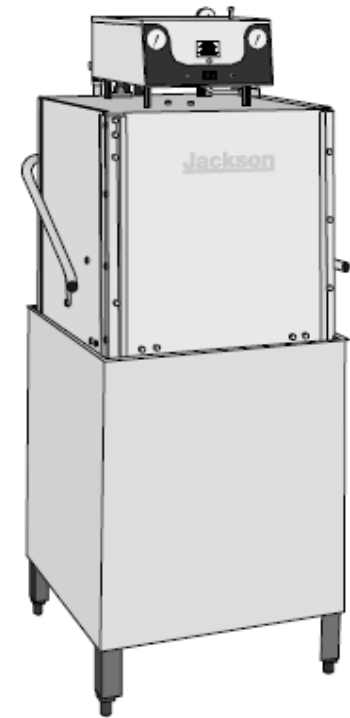

# Refilling dishwashing machine

## **STANDARD:**

Every steward will know how to refill the dishwashing machine safely without doing damages to it or him/herself.

# Refilling dishwashing machine

## PROCEDURE:

- ❖ Assure that the machine is clean by opening inspection doors.
- ❖ Check that all scrape baskets and trays are cleaned and placed correctly.
- ❖ Check that wash arms and curtains are cleaned and fixed properly.
- ❖ Check that detergent and rinse aid dispensers are filled with chemicals.



# Refilling dishwashing machine

## PROCEDURE (continued):

- ❖ Close the drain and switch on the fill switch.
- ❖ When the tank is filled with water start the machine and run it for a few minutes to mix the chemicals and to check the machine is running properly.
- ❖ Check the thermometer dials to ascertain wash tank are correct temperature (50 to 60 degrees centigrade for pre – wash, 65 to 70 degrees centigrade for wash and 82 to 90 degrees centigrade for final rinse).



# Refilling dishwashing machine

## **NOTE:**

If there is a problem in the dishwashing machine such as chemical pumps not working, safety switches not functioning, water not pumping, out of wash arms etc, please report it immediately to your supervisor who will then call engineering to fix the problem.

# Setting up bussing station

## **STANDARD:**

All bussing stations will be set up in a timely manner. That is with cup, plate, glass & cutlery racks, pre-soaking container and garbage bins. It will be kept neat and tidy at all time.

# Setting up bussing station

## **PROCEDURE:**

- ❖ Take a clean and sanitized garbage bin and insert garbage bag in it.
- ❖ Mix cutlery presoak chemical in the presoak cutlery tank and place an open rack for silver flatware.
- ❖ Mix cutlery presoak chemical in a plastic bussing container for stainless steel flatware.

# Setting up bussing station

## **PROCEDURE (continued):**

- ❖ Set up the glass, plate, cup and cutlery racks and baskets.
- ❖ Set up empty bottle racks supplied by outlets.
- ❖ Set up the decoy system for bussing.

## Setting up bussing station

### **REMEMBER:**

Bussing table is not a garbage disposal; keep bussing table and floor clean and tidy at all time.

# Scrapping, racking and loading the dishwasher

## **STANDARD:**

Every steward will know how to scrape, rack and load the dishwashing machine safely and keeping breakage and dirt to a minimum at the warewashing station.

# Scrapping, racking and loading the dishwasher

## **PROCEDURE:**

### Scraping and Racking

- ❖ Scrape all food soil from the plates at the bussing station.
- ❖ Rack dishes of the same size together in the dishwashing rack. Place them in straight row, do not overload or overlap.
- ❖ Place cups, glasses, bowls etc upside down in the racks. Do not mix or stack them on top of one another.



# Scrapping, racking and loading the dishwasher

## **PROCEDURE (continued):**

### Scraping and Racking

- ❖ Soak all flatware in an open rack for 10 – 15 minutes in the pre-soak chemical container.
- ❖ Place flatware with handles down and eating end up in the basket with knives, spoons and forks mixed together so that they do not nest and can be washed clean.

# Scrapping, racking and loading the dishwasher

## **CAUTION:**

Be careful to not mix silver, stainless steel, glasses and crockery's together as they can be easily damaged inside the dishwasher.

These items are very expensive and should be handled with care.

# Scrapping, racking and loading the dishwasher

## Loading the Dishwashing Machine

- ❖ Rinse all items with overhead sprayer.



- ❖ Slide all racks into the dishwashing machine.
- ❖ After wash and rinse cycle, allow dishes to drain and air dry for several minutes.
- ❖ Tilt cups and glass racks to drain excess water from the recessed bottoms.

# Scrapping, racking and loading the dishwasher

## Loading the Dishwashing Machine (continued)

- ❖ Remove clean dishes from the racks and stack them in their proper storage places.



- ❖ Check to see flatware's are clean and dry. Sort them out by types such as knives, spoon, forks etc and place them in their appropriate racks flat or eating end down and handles up in the baskets.

# Cleaning the dishwasher and the traps inside the machine

## **STANDARD:**

The dishwasher shall be kept in hygienically clean condition at all times, enabling complete hygienic warewashing and keeping the machine repairs to a minimum.



# Cleaning the dishwasher and the traps inside the machine

## **PROCEDURE:**

- ❖ Turn off the dishwashing machine ensuring the main switch is also switched off.
- ❖ Open the drain valve to allow the machine to drain.
- ❖ Take out all strainer traps and scrape basket, keeping level so as not to drop any left over food soils into the tanks.
- ❖ Invert the traps over garbage bin and shake out contents and make sure there are no utensils or cutleries amongst the contents.
- ❖ Rinse the empty traps over the sink to make sure all dirt and foodstuff deposits are removed.
- ❖ Check empty wash tanks for any soils or cutlery that may have slipped in between traps out in the tank.

# Cleaning the dishwasher and the traps inside the machine

## PROCEDURE (continued):

- ❖ Remove the curtains, upper and lower wash arms and rinses arms and clean them thoroughly. Ensure there is no debris or food soil trapped in wash arms.

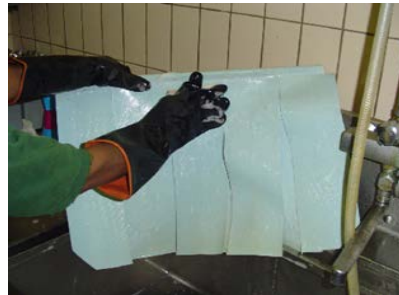

- ❖ Clean the dishwasher thoroughly giving special attention to edges, corners and ceiling inside the machine.
- ❖ Replace scrap baskets, scrap trays, wash and rinse arms and curtains; clean the machine surface and surroundings as per their cleaning procedure.

# Cleaning the dishwasher and the traps inside the machine

## **CAUTION:**

Do not hose down or use water bluster in cleaning the outside part of the dishwashing machine, as it has got electrical parts, which can cause damage.

# Avoid Breakages

## **STANDARD:**

All stewards will work together to keep breakages to smallest amount possible through proper handling and storage.

# Avoid Breakages

## **PROCEDURE:**

- ❖ Be familiar with the right type of racks for each piece of glassware and crockery.
- ❖ Never stack in a dangerous manner i.e. too high or too close to edge or on a damaged trolley or unsecured shelves.
- ❖ Never stack glasses or cups double in their racks.
- ❖ Never throw any items.
- ❖ Never push a trolley with crockery or glass if your sight towards your destination is invisible.
- ❖ Never run with rolling stock loaded or unloaded.
- ❖ Always ask for help to lift heavy items.
- ❖ Make sure people working with their back to you know of your presence.

# Avoid Breakages

## **PROCEDURE (continued):**

- ❖ Take corners slowly making sure nothing is in your way.
- ❖ Be very careful on slippery surface.

# Avoid Breakages

## **REMEMBER:**

These items are very expensive and it is not easy to be replaced.